

G.V.W.R.	59,800#	Axle	(2) 22,500# Dual Wheel Air Brake - Oil Bath
G.A.W.R. (Ea. Axle)	18,160#	Supension	44K Adjustable
Coupler	SAE 2" Kingpin	Tire	ST215/75 R-17.5 Load Range H
Jack	Adjustable 4 Position Landing Legs	Wheel	6.75 x 17.5, 10 Bolt Budd
Neck	16" 31# I-Beam	Floor	2" Nominal Oak (S4S)
Frame	16" 31# I-Beam	Lights	LED D.O.T. Stop, Tail, Turn & Clearance
Crossmembers	10" 12# I-Beam	Elec. Plug	7-Way Semi Style Socket
Side Rails	12" Channel	Finish (Prep)	Steel is Cleaned to Ensure a Professional Smooth Finish.
		FINISH	Superior Quality Finish is Applied for a Highly Decorative and Protective Finish.

Standard Features

- Modular Sealed Wiring Harness w/Junction Box
- Safety Reflective Marker Tape
- 102" Wide
- Low Profile Bed
- 12" Channel Side Rails
- 2 Side Bed Steps
- Oak Flooring
- 8 - 1" O.D. D-Rings
- Heavy Duty Oil Bath w/12-1/4" x 7-1/2" Air Brakes, Including Automatic Slack Adjusters & Spring Brakes on Both Axles
- Anti-Skid Brake System on Front Axle
- 3' Dove Tail w/5' Double Hinged Spring Assist Ramps
- Grommet Mount Sealed LED Lighting

Description

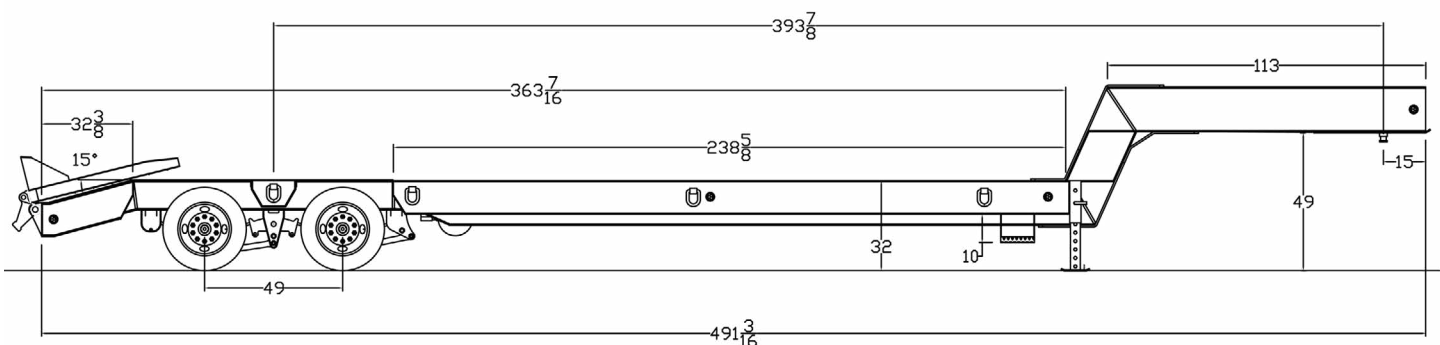

5XGL Lowboy Heavy Equipment Transport ●



Shown with full width neck option and plate over tires

Model	Weight*	Description
*5XGL-20+3	11,600#	102" x 20' Equipment Transport

*Weights shown are for base models without options and are estimates only

Optional Equipment

Category	Description
JACKS	Dual Two Speed Landing Gear Jacks (50K)
TIRE/WHEEL	Spare Tire (ST215/75 R-17.5 LR-H Dual)
BRAKES	ABS on 2nd Axle
BODY	Full Width Neck
BODY	Plate Over The Tires (Raises bed height by 2")
CARGO CONTROL	1" D-Ring (Each)

*** Trailer is subject to Federal Excise Tax**